

# 61 SERIES

## Multi Stack Filter Housing





The **61 Series** multi cartridge housing is available with 3, 5, 10, 15 and 19 element stacks up to 40" long. The top opening style is equipped with a Cast Vee clamp as standard for pressures up to 10 bar g.

These housings are widely used where low capital cost is of prime importance. Being floor mounted and therefore free standing, these housings will suit most pre-filtration applications. Bolted closures are an option available for all models.

The **61 Series** will accept either standard Double Open End or Single Open End cartridges. This includes the full range of Amazon and industry standard cartridges ranging from 0.1 to 500µm with nominal lengths of 10, 20, 30 and 40".

Accessories available include pressure gauge and vent valve kits, drain valves and bolt down plates.

Accessories	Part Number
Pressure Gauge and Vent Valve Kit 	60S000016
Pressure Gauge and Auto Vent Valve Kit 	60S000082
Ball Valve and Nipple 	60S000010

### Product Features

- Free standing, easy to install design
- Universal cup allows the use of plug in (Code 3 and Code 8) or DOE cartridge styles in the same housing
- Vee clamp closures use unique 'W' style seal for reliable leak free operation (Not available on 6119)
- High quality cast Vee band clamps for safety and security (Not available on 6119)
- Cast compression nut with integral PTFE washer for easy, hand tight cartridge sealing
- Wide range of connection sizes and types, cartridge lengths and materials of construction
- WRAS Approved product



## Features and Benefits

- Integral vent, clean and dirty drain sockets to aid efficient filter changeout
- Universal cup enables choice of plug in (Code 3 and Code 8) or DOE cartridge styles in the same housing
- Every housing is etched with a unique serial number for full traceability
- Available in 316L Stainless Steel
- Full housing customisation service available
- Internally and externally electropolished as standard
- WRAS Approved product

## Product Range

Amazon Filters design and manufacture an extensive range of liquid filtration systems, providing one of the widest selections of filtration vessels, depth filters and pleated cartridges available today, ensuring excellent process and filter compatibility. As one of Europe's leading manufacturers of filtration systems, Amazon Filters is able to offer a solution to meet all filtration requirements. Amazons' filters are manufactured in clean room conditions and all products come with detailed Product Validation Guides and Technical Support documentation.



**AMAZON**

# 61 Series Technical Data

## Maximum Operating Conditions

	6103	6105	6110	6115	6119
Liquids: Vee clamp:	10 bar g	10 bar g	10 bar g	7 bar g	-
Bolted closure:	FV/10 bar g	FV/10 bar g	FV/10 bar g	FV/10 bar g	FV/6 bar g
Gases: Vee clamp:	7.5 bar g	4.5 bar g	2 bar g	1.5 bar g	-
Bolted closure:	FV/7.5 bar g	FV/4.5 bar g	FV/2 bar g	FV/1.5 bar g	FV/1 bar g
Temperature Range:	-10°C / 150°C				

## Materials of Construction

Body:	316L St.Steel
Closure:	Vee Clamp - 304 St.Steel Screw Clamp - Zinc plated carbon steel (Optional Stainless Steel)
Vessel Finish:	Electropolished

## Connections

	6103-05	6110	6115-19
Inlet/Outlet:	2" BSPM	3" Flange	4" Flange
Vent:	1/4" BSPM	1/4" BSPM	1/2" BSP
Drain:	1/2" BSPM	1/2" BSPM	1" BSPM

## PED Status:

Fluid Groups:	Compliant with 97/23/EC Liquids Group 2 Gases Group 2
Marking:	CE Marked

## ATEX:

Compliant 94/9/EC, level CE Ex II 2 GD c X

Technical drawings for each individual housing showing dimensions, volume, weights, maximums and design pressures available on request.

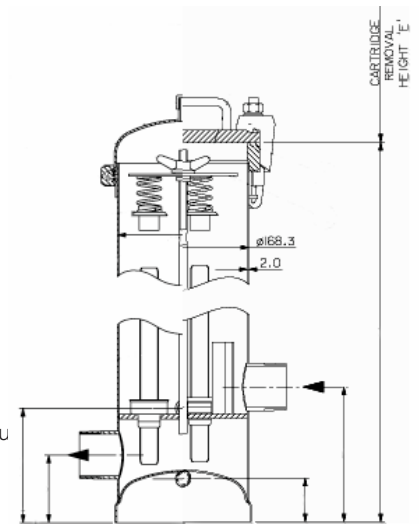
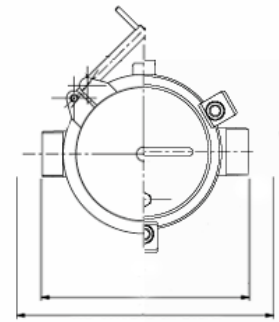

# AMAZON FILTERS LTD.

ALBANY PARK ESTATE, FRIMLEY ROAD  
CAMBERLEY, SURREY, GU16 7PG  
ENGLAND

**Tel.** +44 (0) 1276 670600  
**Fax.** +44 (0) 1276 670101  
**Email.** sales@amazonfilters.co.uk  
**Web.** www.amazonfilters.com